



# RIPR NAS

RECORDER, INTEGRATED PROCESSOR, AND ROUTER  
NETWORK ATTACHED STORAGE (NAS) | 1403 SERIES



# RIPR NAS 1403 SERIES

## Recorder, Integrated Processor, and Router Network Attached Storage (NAS)

The 1403 RIPR NAS delivers multi-channel, multi-format recording with modular I/O expansion for air, sea and land platforms. Built on Spectra's field-proven data acquisition foundation, the 1403 combines digital and analog recording capabilities with integrated processing and routing in a compact, stackable form factor.

The baseline controller provides essential data and video I/O. Stackable I/O modules expand capabilities to match specific mission requirements — from ISR data collection to flight test instrumentation.

Field-configurable architecture enables mission-specific deployment across commercial and military applications.

### KEY FEATURES

**Baseline controller module** includes the most commonly requested control and data acquisition interfaces, providing a flexible foundation for a wide range of applications. Standard interfaces include:

- 4 channels of 1Gb Ethernet
- 2 channels of RS-232/422 communications
- 2 channels of MIL-STD-1553 MUX bus
- 2 channels of PCM RS-422 differential input
- 2 channels of analog audio
- 8 discrete inputs and 8 discrete outputs

The module features two programmable PCM RS-422 output channels, capable of streaming PCM data in multiple formats, including CH7 TM output, Ethernet over Serial Streaming (EOSS) HDLC, or CH4 PCM.

#### **Baseline controller module**

Time Synchronization over Ethernet IEEE-1588, IRIG B/G AM or DC, MIL-STD-1553, or with integral GPS Receiver providing both time sync and TSPI record. Controller includes features to support Data At Rest (DAR AES-256 encryption support), including connectivity to load passwords, discrete switches to erase passwords and LEDs to provide key status.

#### **Ethernet and serial control and status**

- Easily reprogram MAC and IP addresses, vary link types and speeds
- Integrable device status for real-time monitoring of all data links
- Ethernet publish of any recording channels selected

#### **Customized COTS data and video I/O**

The 1403 RIPR NAS can be configured with up to 4 stackable COTS I/O modules. Modules are offered to include 8 channels of RS422 or single-ended PCM, 8 Channels Mil-Std 1553, 8 Channels Std Def Video, 16 Channels ARINC 429. Other data types available upon request.



### APPLICATIONS

#### **Integrated Sensor System Recording**

EO, IR, Radar, EW, HUD/HMD/HDD

#### **Flight Test Instrumentation**

Analog & digital sensors, avionics & weapons busses, video sources

#### **Training and Mission Debrief**

Weapons employment data, EW detection and avoidance

#### **Command and Control**

Real-time video capture and streaming, open architecture API

All data subject to change without notice

1403 RECORDER, INTEGRATED PROCESSOR, AND ROUTER NETWORK ATTACHED STORAGE (NAS)

**KEY FEATURES, cont'd**

**Rugged MIL-STD performance**

Qualified for operations in the harshest of environments, delivering assured performance through high shock, vibration and other environmental hazards.

**Minimized SWaP**

The 1403 RIPR NAS offers an advantage in platforms and pods that require minimized SWaP and maximized processing capabilities. Baseline power supply is 28 vdc 75 W with 50 ms holdup — recorder can be powered directly with 5 vdc source.

**Removeable Medias**

Removable Memory Modules available in capacities 1TB, 4TB, 8TB, or 16TB using PCI Gen 4 NVMe based AES256 self-encrypting drives.

**Recorder Media Format** — NFS, recording each channel as a separate file for direct transfer to a laptop or desktop computer for decommutation.

**QUALIFICATIONS & SPECIFICATIONS**

**MECHANICAL DETAILS**

**Weight** Min. 4 lbs (1.814 kg) No stack modules w/out manifold  
Max 8.4 lbs (3.81 kg) 4 stack modules w/manifold

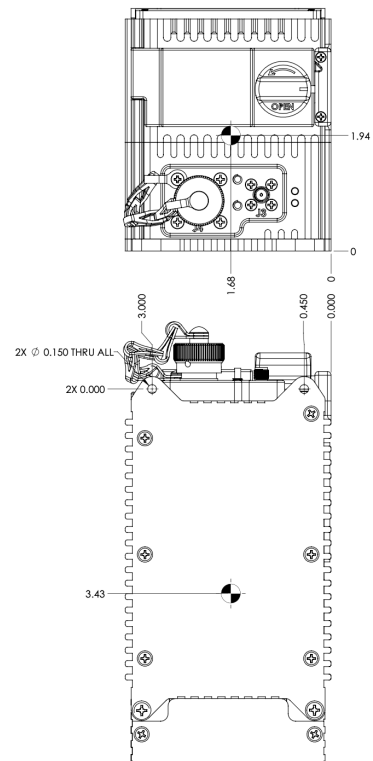
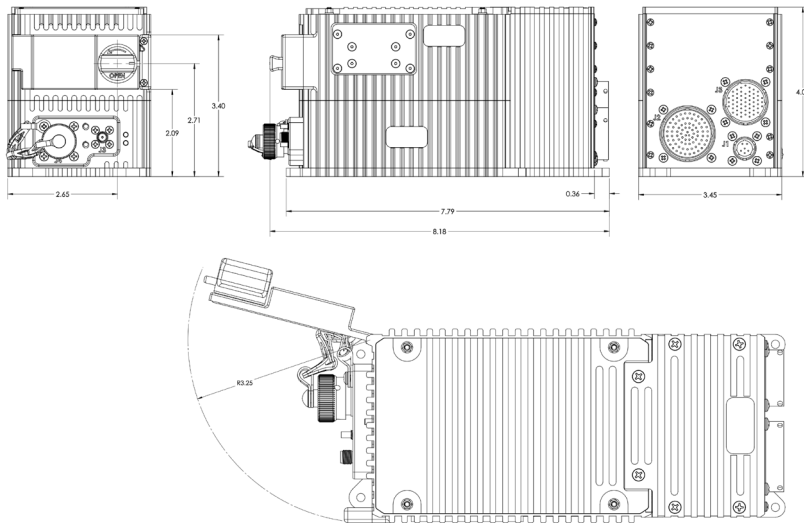

**PRODUCT QUALIFICATIONS**

<b>Environmental</b>	Per MIL-STD-810	<b>Explosive Atmosphere</b>	511.7 Procedure I
<b>Altitude</b>	70,000 ft (Operational)	<b>Acceleration</b>	Procedure II
<b>Temperature</b>	-40°C to +71°C Operational, -55°C to +95°C Storage	<b>Vibration</b>	514.8, Cat 12
<b>Humidity</b>	5% to 95% non-condensing	<b>Shock</b>	516.8, Proc I 20Gs and Proc V 40Gs
<b>Fungus</b>	508.8, Inert	<b>Gunfire Shock</b>	519.8, F-16 Profile
<b>Salt Fog</b>	509.7, 24 hrs, +35°C	<b>EMI per MIL-STD-461</b>	CE102, CS101, CS114, CS115, CS116, RE102, RS103
<b>Sand &amp; Dust</b>	510.7 Procedure I & II	<b>EMC per MIL-STD-704</b>	28 VDC: Compliant w/50 msec holdup



# **SPECTRA**

*Defense Technologies*

Spectra Defense Technologies is a global provider of leading C5ISR solutions for aerospace and defense customers. With over 35 years of proven performance and differentiated expertise, we deliver fully integrated mission systems, data recorders, secure networking, edge computing, robust data-at-rest encryption and advanced visualization that capture, process, and display mission-critical data across air, land, sea, and space.

Backed by engineering, sales, and production teams in North America and Europe, Spectra combines global reach with agile innovation to meet evolving end-user needs with speed and precision. Guided by a culture of innovation and deep customer partnership, we build enduring trust through open-architecture designs, technical excellence, and resilient systems designed to meet today's mission needs and anticipate tomorrow's demands for the U.S. DoW, NATO, European defense organizations, and allied partners worldwide. Visit [spectradefense.tech](https://spectradefense.tech) to learn more.

## **CONTACT**

[sales@spectradefense.tech](mailto:sales@spectradefense.tech)

Learn more at  
[spectradefense.tech](https://spectradefense.tech)

